

S6C-5	S6C-10
S6C-20	S6C-30
S6C-40	S6C-50

Fixture Type:

The Shakespeare CDM 5°, 10°, 20°, 30°, 40° and 50° fixed focus ellipsoidals are truly state of the art luminaires in style, versatility of functions and efficiency. Configured with a 39W, 70W, or 150W ballast, these lighting fixtures with their respective Ceramic Discharge Metal Halide Lamps will direct bright, sharp or soft-edged illumination to their subject.

Each unit has two accessory slots and at least one accessory holder on the lens barrel. The slot nearest to the lamp is specifically sized to accept pattern holders for metal gobos with 2 5/8" image diameters ("B" size). The second slot, which has a cover to eliminate light leaks when not in use, will accept either a glass pattern holder, drop-in iris, gobo rotator or a dual gobo rotator. Both the 5° and the 10° Shakespeare CDM units have generous sized front accessory holders with self-closing and self-latching safety retainers. These accessory holders are large enough for color frames, glass color frames, donuts, snoots or color changers and combinations of accessories as required. The 20°, 30°, 40°, and 50° fixed focus units have replaceable accessory holders with two separate channels. The lens barrels are interchangeable without the use of tools, and there is a unique safety latch to prevent the accidental removal of any lens barrel.

These low wattage, long lamp life units produce a cool light with a high color rendering index that will not seriously impact ambient temperatures. Ideally suited for projecting company logos, spotlighting and enhancing physical logos and signs or lighting trade show booths, products and goods.

Specifications subject to change without notice



S6C-20-110-150  
pictured

39/70/150 WATT  
**SHAKESPEARE  
FIXED FOCUS CDM**  
Features

- 12,000 hour CDM lamp with high color rendering index
- Compact, rugged die-cast aluminum construction, & spun aluminum construction on 5° and 10° only
- Lockable, 180° Indexed rotation of shutter assembly and lens barrel, optional 360° rotation
- Tool free Interchangeable lens barrels provided with unique safety retaining latch
- Color coded lens & lens barrel identification system
- Tempered crown glass lenses have anti-reflective coating
- Tool free operating lamp centering knob and peak or flat field adjustment knob
- Replaceable two slot accessory holder (20°, 30°, 40° and 50°) & wide slotted accessory holder for 5° and 10° provided with self-closing and self-locking accessory retaining latch
- Accessory slot provided with locking cover that will accept rotation gobo accessories, glass pattern holder and drop-in iris
- Tool free removable heavy gauge stainless steel shutters in separate planes equipped with oversized insulated handles, and spring pressured shutter assembly
- Dual positioning yoke supplied with dual positive locking dog and pivot angle markings.
- Protective insulated rear mounted ring handle serves as cord wrap, stand, and focusing aid
- G9.5 medium two-pin lampholder provided with heat shield and accepts a wide variety of non-proprietary lamps
- Uses standard 6 1/4" accessories for 20°, 30°, 40° and 50°, 12" for 10°, and 14" for 5°
- 36" lead of 3 conductor cable
- Color frame and safety cable included
- U.L. and c.U.L. listed with their respective lamps
- Made in the USA

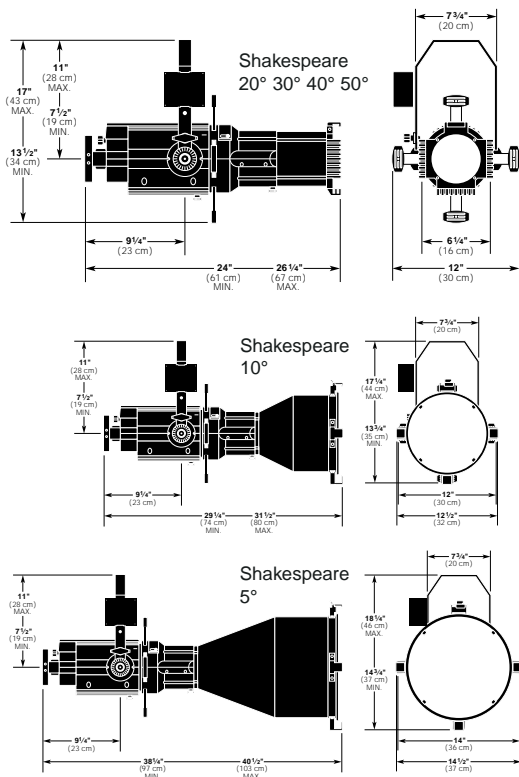

# 39/70/150 WATT SHAKESPEARE FIXED FOCUS CDM 5° 10° 20° 30° 40° 50°

## Specifications

**Housing:** Die-cast aluminum.

**Materials:** Construction employs corrosion resistant materials and hardware.

**Yoke:** Rigid flat steel with dual locking dog tilt handles, two mounting positions, indexed pivot angle markings.

**Reflector:** Alzak aluminum, ellipsoidal design.

**Lenses:** Color coded white plate glass with anti-reflective coating. 5° and 10° fixtures utilize polymeric plastic to reduce unit weight and front end leverage.

**Lens Barrel:** Die-cast aluminum with spun aluminum extensions for the 5° and 10° units.

**Lamp/Socket:** 39W, 70W or 150W UV Block G12 Ceramic Metal Halide lamp. 5kV pulse rated socket.

**Ratings:** 120 volt AC operation; 50/60Hz .38 amps with 39W lamp and 39W ballast; .58 amps with 70W lamp and 70W ballast; 1.25 amps with 150W lamp and 150W ballast. 240 and 277 VAC units are available.

**Ballast:** Aromat Corp. 39W, 70W and 150W NAIS DCP Electronic Ballasts. Unit carries a full 5 years warranty tested and approved by Aromat.

**Cable:** 4 feet of insulated 3 conductor cable.

**Lamp Alignment:** fully adjustable in three axis with the use of two heat resistant concentric knobs. Tool free lamp replacement.

**Focusing:** Lens barrel travels on nylon glides and friction locks using a heat resistant knurled knob.

**Accessories:** Front end accessory holder accepts 6 1/4 inch accessories for 20°, 30°, 40°, and 50° luminaires 10° fixture accepts 12 inch and 5° fixture accepts 14 inch accessories.

**Finish:** Black epoxy sandtex, electrostatic application.

### Weights:

Approx; 21 1/2 lbs. (9.7 kg.) for S6C-5°.  
 Approx; 21 1/2 lbs. (9.7 kg.) for S6C-10°.  
 Approx; 20 lbs (9 kg.) for S6C-20°, 30°, 40°, & 50°.

## ORDERING INFORMATION:

Model	Color	Lens	Voltage	Wattage
<b>Part Number</b>	<b>S6C</b>	-	-	-
	(W)hite	(5)Degrees	110	39
	(S)ilver	(10)Degrees	240	70
	(X)custom	(20)Degrees	277	150
		(30)Degrees		
		(40)Degrees		
		(50)Degrees		

## ADDITIONAL ACCESSORIES

TEN-CFB	Black Color Frame, 12" x 12" (for S6-10)	71-0500	Fixture Body without Lens Barrel
TWE-CFB	Black Color Frame, 14" x 14" (for S6-5)	71-0501	50° Lens Barrel w/Lenses
510	Malleable Iron Pipe Clamp	71-0502	40° Lens Barrel w/Lenses
4.5-DN	Donut 6 1/4" x 6 1/4" w/2 1/2" diameter opening	71-0503	30° Lens Barrel w/Lenses
TEN-DN	Donut, 12" x 12" w/5" diameter opening (for S6-10)	71-0504	20° Lens Barrel w/Lenses
TWE-DN	Donut, 14" x 14" w/6" diameter opening (for S6-5)	71-0506	10° Lens Barrel w/Lens
4.5-SN	Snoot	71-0507	5° Lens Barrel w/Lens
TEN-SN	Snoot (for S6-10)	90-35CDMT6/830	39 Watt CDM Lamp 3000K-12,000 Hr.
360-PH	Pattern Holder with Channels 2 1/4" diameter opening, 3 3/8" wide	90-70CDMT6/830	70 Watt CDM Lamp 3000K-12,000 Hr.
1KL6-PH	Pattern Holder with Slots, 2 1/4" diameter opening, 3 3/8" wide	90-70CDMT6/942	70 Watt CDM Lamp 4000K-12,000 Hr.
S6-GPH	Pattern Holder for Glass Patterns	90-150CDMT6/830	150 Watt CDM Lamp 3000K-12,000 Hr.
404.4.5	Motorized Color Wheel	90-150CDMT6/942	150 Watt CDM Lamp 4000K-6,000 Hr.
SDii	Drop-in Iris	90-150CDMSA/942	150 Watt CDM Lamp 4200K-5,000 Hr. Short Arc

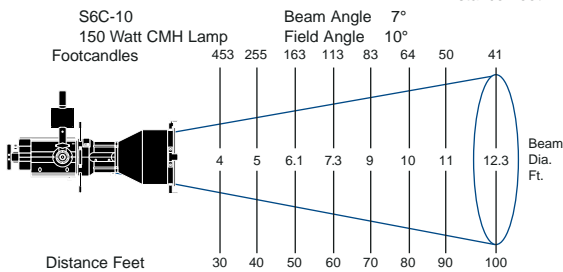
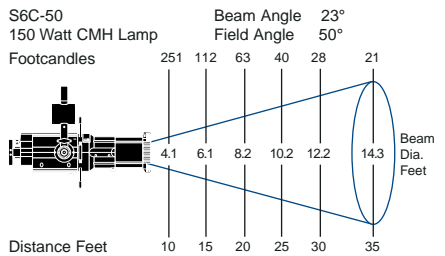
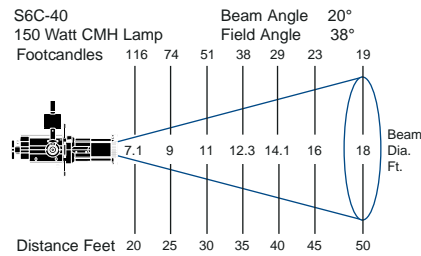
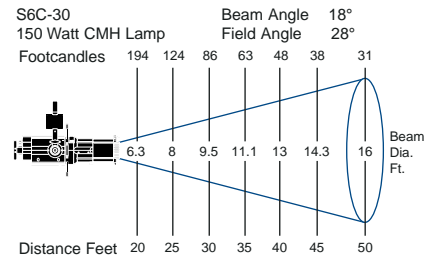
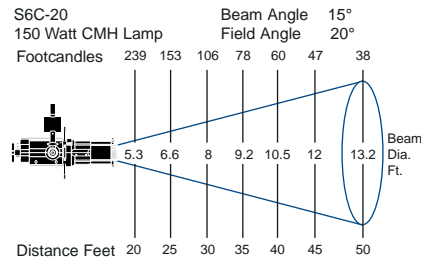

Conversion Factors	
39 Watt Lamp = f.c. x .24	
70 Watt Lamp = f.c. x .48	
Lux: = f.c. x .0929	

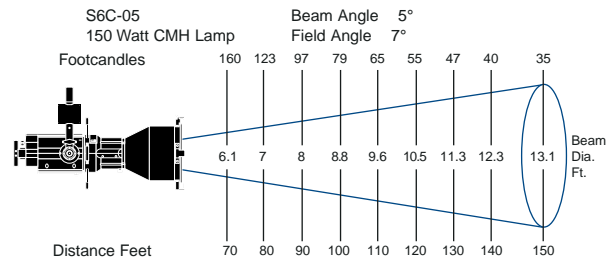

ACCESSORIES Supplied with Luminaire	
4.5-CF	Color Frame, 6 1/4" x 6 1/4" (for 20°, 30°, 40° & 50°)
TEN-CF	Color Frame, 12" x 12" (for S6-10)
TWE-CF	Color Frame, 14" x 14" (for S6-5)
SC	Safety Cable with Spring Clip

## LAMP DATA

Lamp Type	Watts	Efficiency	Color Temp (°K)	Rated Life (Hours)	Rated Lumens	Color Rendering Index	Burn Position
CDM 35/T6/830	39	>87 LPW	3000	12,000	3,400	81	Any
CDM 70/T6/830	70	>92 LPW	3000	12,000	6,600	82	Any
CDM 70/T6/942	70	>92 LPW	4000	12,000	6,600	92	Any
CDM 150/T6/830	150	>93 LPW	3000	12,000	14,000	85	Any
CDM 150/T6/942	150	>85 LPW	4000	6,000	12,700	95	Any
CDM SA150/T6/942	150	>86 LPW	4200	5,000	12,900	96	Any