

CURTAIN TRACK

Ordering Curtain track involves a few basic considerations.

Some of these are:

Will the track require a draw cord or will it be a walk-along?

How much storage space is required to store the drapery?

What is the length of the draw cord?

Draw curtains are normally bi-parting front, back, or mid-stage curtains; or one-way draw scrims and cycloramas.

Walk-along curtains are usually cycloramas or back curtains and do not require a draw cord.

To determine the length of a draw cord, add the total length of the track and the height from the track to the floor. Double this figure and add a 2% safety factor. It is much better to have a little extra cord.

To determine the length of track required for a bi-parting curtain; take the length of the proscenium opening, add 20% for stacking curtains at the ends **and** 4 feet for the center overlap.

Stacking space for drapery is determined by adding the length of the master carrier, approximately 3 inches, the length of the end pulley, 4 to 6 inches, the stacking space for each carrier, 1 to 2.5 inches, plus an additional 10% allowance for fabric bunching.

Curtain track is sold on a per foot basis, with necessary parts for a standard installation. For a bi-parting curtain this includes the track channel, cut to the nearest foot, one pair of master carriers, one single carrier per foot of track, one live end pulley, one dead end pulley, one tension floor pulley, two overlap clamps, necessary hanging clamps, two end stops and cord support, and curtain cord as specified.

CYCLORAMA SYSTEMS

Cyclorama tracks are equipped with curtains which are normally hung at the sides and rear in order to enclose an area on three sides. I beam track is used for stage and studio cyc installations where the operator walks the curtain to an open or closed position. The track can be factory curved or curved on-the-job. No cord or pulleys are supplied with "walk-along" track.

PREMIER is happy to loan a bending tool with the purchase of curtain track. A full value deposit is required.

STANDARD DUTY CURVED TRACK

An all-purpose, medium duty track which can be used as a walk-along or a draw curtain. When used as a cyclorama draw curtain, the method of installation, the radius of the curves and the type of fabric being used become critical. We recommend that you send a sketch and specifications prior to ordering. This is a very versatile, I-beam aluminum track

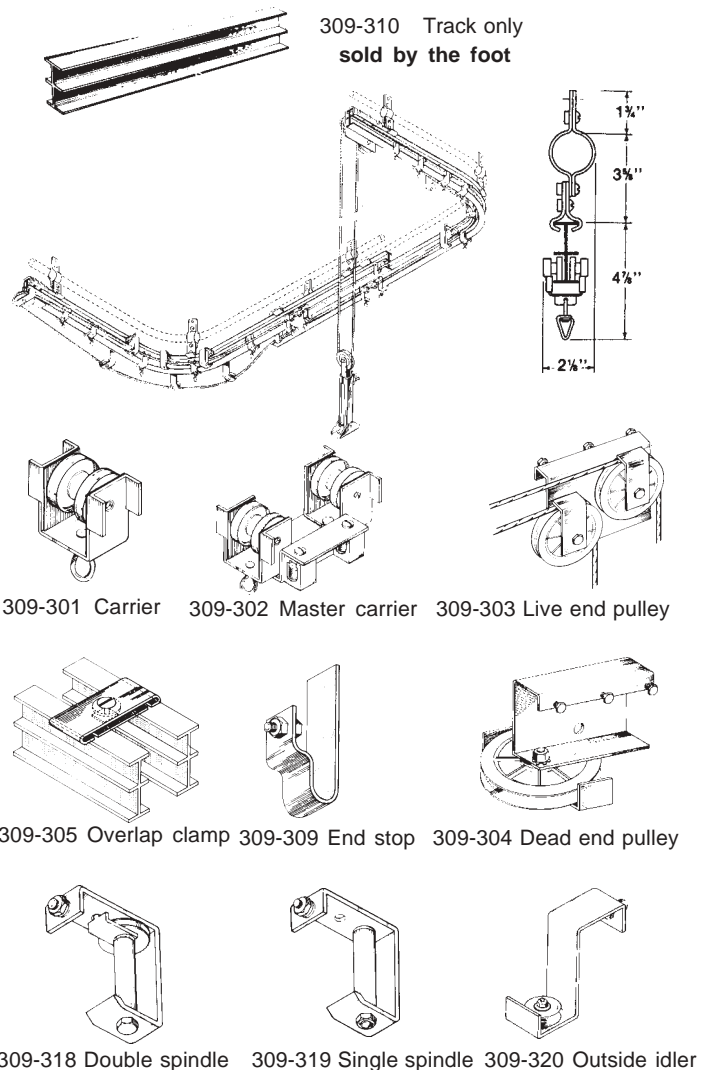

- Additional Parts
- 309-306 Clamp Hanger
 - 309-307 Splice
 - 309-308 Tension Floor Block
 - 309-311 Ceiling hanger
 - 309-315 Draw cord

If you are buying Curtain Track for the first time, please call, we will be happy to assist you.

CURTAIN TRACK

STANDARD DUTY STRAIGHT TRACK

Steel or aluminum channel used in installations using light and medium weight draw curtains. May be factory curved for a walk-along system. Ideal for rooms which have a low ceiling and a continuous draw curtain is desired; overlap master carriers are used instead of two over-lapping track sections.

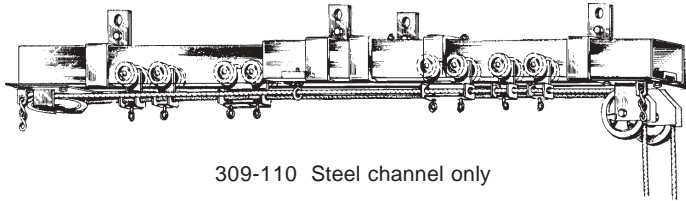

309-110 Steel channel only

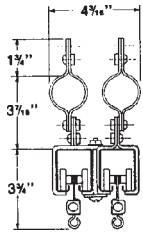

309-101 Carrier



309-102 Master Carrier



309-103 Live end pulley



309-104 Dead end pulley

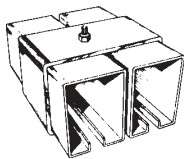

309-105 Overlap clamp



309-108 Adjustable floor block



309-132 Overlap master carrier

- Additional Parts
 309-106 Clamp Hanger
 309-107 Splice
 309-109 End stop & support
 309-160 Pivot device
 309-445 Pipe Clamp (for 1.5" ID pipe)

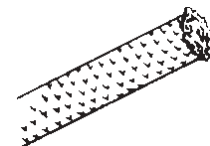

309-115 Operating cable wire center

Please call for information on
Heavy Duty Straight & Curved Track.

LIGHT DUTY CURVED TRACK

(walk-along only)

This light duty cyclorama track is ideal for closed-circuit TV in schools, small stages, multi-purpose rooms, cafeteriums, and corporate offices where a curved walk-along operation is required. It can be factory curved, but is ideally suited to be curved on-the-job.

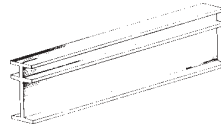

309-710 Track only

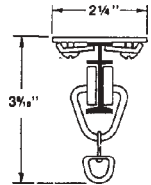

309-701 Carrier

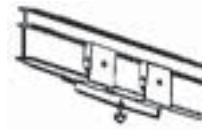

309-702 Master carrier pair



309-706 Clamp hanger



309-707 Splice

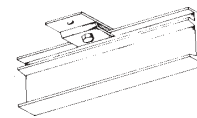

309-711 Ceiling hanger

309-709 End Stop

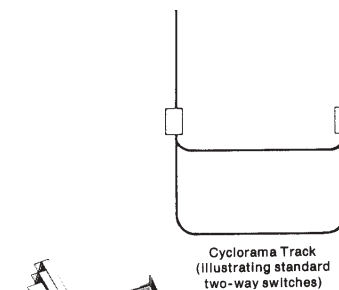

Cyclorama Track (illustrating standard two-way switches)



DRAW CURTAIN MACHINE

Instant reversing motor operates at a speed of 86 ft/min. Built in limit switch with chain guard to automatically pre-set desired travel of curtain.

SWITCHER

Use to transfer drapes from one track to another for flexible setup or storage offstage.

FABRICS & DROPS

This selection of material represents only a few of the many types of stage and studio fabrics we supply. **Fabric is sold by the linear yard**, or we can fabricate any material into curtains or drapery to your specification. Please call or write.



SCENERY MUSLIN (medium weight)

Unbleached muslin is used for covering scenery, flats, and constructing cycs and backdrops. The natural color is cream white. Non-flameproofed muslin will shrink up to 4% to 9% when flameproofed. Wide widths may be slit length-wise to make a narrower, economical covering. Sold by the linear yard.

- 350-112 95" wide, Flame-retardant treated (3 yd. minimum)
- 350-115 84" wide, NON-flameproofed (4 yd. minimum)
- 350-221 120" wide, NON-flameproofed (4 yd. minimum)

Blue, bleached white, 60% reflectance grey and very wide muslin fabrics are available on a quotation basis. Please call for pricing & availability.

MUSLIN STANDARD DROPS

These standard size drops are constructed of Flame-retardant Muslin sewn flat with vertical seams. Webbing, grommets and ties 12" centers at top finish. Chain in a lined hem at bottom (or pipe pocket) and 2" side hems. Please allow 1-2 weeks for shipment.

- 352-100 15' high by 30' wide natural muslin drop
- 352-150 15' high by 45' wide natural muslin drop



SCRIM

Used for fantasy and transitional effects. Scrim appears transparent when lit from the front, but becomes opaque when lit from the back. Sharktooth scrim is also used as a seamless cyc fabric that serves to diffuse and reflect stage or set lighting. Sold by the linear yard. Please allow 1 day for cutting.

- 350-910 White, 31' wide, flameproofed
- 350-915 Black, 31' wide, flameproofed

THEATRICAL GAUZE

A light beige (natural) colored, loose weave, fabric that performs like scrim material. Sold by the yard

- 350-610 Natural, 66" wide, flame-retardant



CHROMA KEY FABRIC

Used for backdrops when shooting television scenes that require special effects and/or a "keyed" background. This polyester material is inherently flame-retardant and is very durable and washable. Sold by the linear yard.

- 350-351 Chroma blue, 72" wide, flame-retardant (2 yd. minimum)
- 350-352 Chroma green, 72" wide, flame-retardant (2 yd. minimum)

REAR & FRONT PROJECTION MATERIAL

A range of rear projection screen materials, each with special properties. Available by the linear yard. Inherently flame-retardant.

- 355-500 Black, 55" wide, seamless
- 355-505 Twin white, 55" wide, seamless
- 355-510 Grey, 55" wide, seamless
- 355-515 Light translucent, 55" wide, seamless
- 355-517 Front White, 55" wide, seamless
- 355-520 Grey, 110" wide (2x55" welded)
- 355-521 Twin White, 110" wide (2x55" welded)
- 355-522 Black, 110" wide (2x55" welded)
- 355-523 Light Translucent, 110" wide (2x55" welded)
- 355-524 Front White, 110" wide (2x55" welded)
- 355-530 Grey, 86" wide, seamless
- 355-531 Twin White, 86" wide, seamless
- 355-532 Front White, 86" wide, seamless

CUSTOM FINISHED SCREENS are ultrasonically welded to your specifications with grommets and pipe pocket.

Delivery is 3 - 4 weeks.

Deposit of 50% is required.

100 square foot minimum.

Dimensions to outside of screen; priced to next largest foot.



DUVETYNE (commando cloth)

A medium weight fabric with a smooth, soft nap. A very economical substitute for Velour. Used for borders, legs, mid-stage draw curtains and a black-out material. Sold by the linear yard.

- 351-205 Black, 54" wide, flameproofed, 8 oz., (10 yd. minimum)
- 351-200 Black, 54" wide, flameproofed, 12 oz. (3 yd. minimum)
- 351-203 Black, 54" wide, flameproofed, 16 oz., (10 yd. minimum)

VELOUR

A heavy pile fabric used for front curtains, drapes, borders, sound insulation and upholstery. Sold by the yard.

Color samples on request.

- 351-405 Black & colors, 54" wide, flameproofed

SPECIALTY CURTAINS & MATERIALS

BRILLIANT MYLAR FOIL

Mylar foil comes in 18" x 50ft. serrated cutter boxes or in 36" x 50 yard rolls. This 1.4 mil, highly reflective designer material is ideal for party decorations and for draping around truss and towers for enhanced reflection of scrolling or moving lights. Self extinguishing plastic.

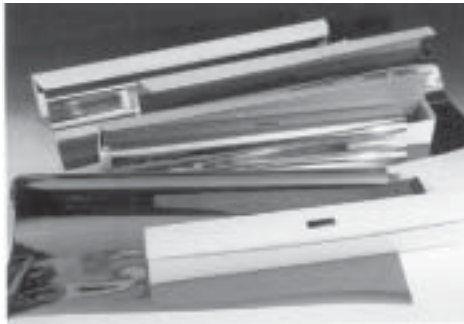

18" x 50 ft.
serrated cutter box

- 355-151 Silver
- 355-153 Gold
- 355-155 Citron
- 355-157 Copper
- 355-159 Bronze
- 355-161 Ice Blue
- 355-163 Flag Blue
- 355-165 Cerise
- 355-167 Metallic Red
- 355-169 Metallic Green
- 355-171 Metallic Purple
- 355-173 Metallic Turquoise
- 355-175 Metallic Burgandy
- 355-177 Snowfall

36" x 50 yard rolls

- 355-183 Gold
- 355-187 Burgandy
- 355-185 Blue
- 355-180 Silver

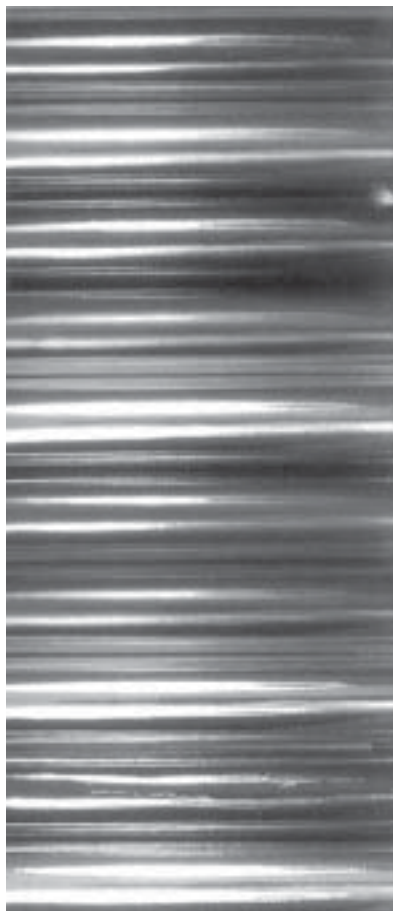

DECORATIVE CURTAINS

Shimmering, metallic decorator curtains. These curtains are flame retardant and faceted for spectacular reflection. Heading is the same material and color as the curtain with a 1/2" spacing to hold a curtain rod or wire frame.



8'H x 3'W

- 356-454 Gold
- 356-460 Silver
- 356-462 Purple
- 356-466 Cerise
- 356-468 Teal
- 356-472 Blue
- 356-478 Green
- 356-484 Red

12'H x 3'W

- 356-490 Gold
- 356-496 Silver
- 356-502 Cerise
- 356-508 Blue
- 356-514 Green
- 356-520 Red

**ADDITIONAL LENGTHS
AND COLORS
AVAILABLE**



SLIT DRAPE

Slashed curtain picks up light and reflects it in a showy fashion. Overlapping 1/8" strips of durable, flame retardant vinyl, make the effect unique.

36" W x 8' H

- 355-457 Gold
- 355-458 Silver
- 355-459 Black
- 355-453 Iridescent
- 355-450 Black/Diffraction
- 355-451 White/Diffraction
- 355-452 Silver/Diffraction
- 355-461 Silver/Iridescent/Gold

36" W x 16' H

- 355-428 Iridescent
- 355-425 Black/Diffraction
- 355-426 White/Diffraction
- 355-427 Silver/Diffraction
- 355-435 Silver/Iridescent/Gold

36" W x 24' H

- 355-408 Iridescent
- 355-405 Black/Diffraction
- 355-406 White/Diffraction
- 355-407 Silver/Diffraction
- 355-415 Silver/Iridescent/Gold